

# PZK (PZ-10) Triplex Drilling Mud Pump



## SPECIFICATIONS

Maximum Input	1,350 BHP (1,007 kw)
Maximum RPM	115 RPM
Stroke Length	10" (254 mm)
Piston Load	139,500 lbs. (620,527 N)
Pump Weight	37,000 lbs. (16,815 kg) average
Gear Ratio	4.38 :1

PISTON CYLINDER		DISPLACEMENT – DRILLING SERVICE				MAXIMUM PSI		PUMP RPM	JACKSHAFT RPM
DIAMETER		PER REVOLUTION		MAXIMUM FLOW RATE					
inch	mm	gallon	liters	GPM	LPM	PSI	bar		
7	178	5.00	18.92	575	2176	3623	250	115	504
6.5	165	4.31	16.31	496	1876	4202	290		
6.25	159	3.98	15.08	458	1734	4545	313		
6	152	3.67	13.90	422	1598	4932	340		
5.5	140	3.09	11.68	355	1343	5000	345		
5	127	2.55	9.65	293	1110	5000	345		

Weight: Complete pump with large steel skid - 41,400 pounds.  
Ratings are based on 90% mechanical efficiency and 100% volumetric efficiency.

**Gardner  
Denver**  
Pumping Perfected.™

# PZK (PZ-10) Triplex Drilling Mud Pump

## OPTIONAL FEATURES

- Steel skid under pump only
- Large steel skid with non-skid decking
- Centrifugal suction charging pump
- Rubber valve inserts
- Suction and/or discharge dampeners
- Oil heat exchanger
- External electric powered lube pump
- Fabricated suction manifold
- Complete package assembly
- Full open valves
- 7500 PSI fluid ends

## SPECIFICATIONS

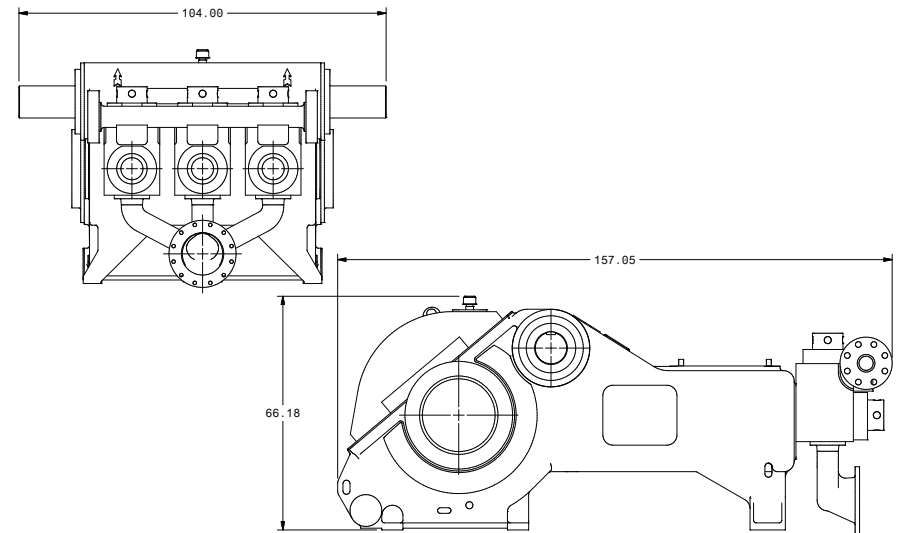

## STANDARD FEATURES

- Nodular iron power frame, eccentric, connecting rods, and crossheads
- Double-row-spherical roller bearings carry eccentric
- Double extended Jackshift carried on heavy-duty straight roller bearings
- Dual roller bearing connecting rod
- Alloy steel main gears are bolted to the eccentric
- Replaceable bronze crosshead slides
- Full splash lubrication, with oil pump to feed working parts
- Heat-treated alloy steel, interchangeable fluid cylinders
- Three-rib API-7 urethane insert valves and seats
- Replaceable-type element oil filter and oil pressure gauge
- Threaded valve covers
- Complete piston washing and lubrication system

## CONNECT WITH US: