

PZL (PZ-11HP) Triplex Drilling Mud Pump



SPECIFICATIONS

Maximum Input	1,600 BHP (1,193 kw)
Maximum RPM	115 RPM
Stroke Length	11 in. (279 mm)
Piston Load	150,300 lbs. (68,175 kg)
Pump Weight	37,000 lbs. (16,815 kg)
Gear Ratio	4.38 :1

5,000 PSI Fluid End Cylinder

PISTON CYLINDER		DISPLACEMENT – DRILLING SERVICE				MAXIMUM PSI		PUMP RPM	JACKSHAFT RPM
DIAMETER		PER REVOLUTION		PER MINUTE		PSI	Kg/sq.cm2		
inch	mm	gallon	liters	gallon	liters				
7	178	5.5	20.82	632	2,392	3,905	275	115	504
6.5	165	4.74	17.94	545	2,063	4,529	318		
6	152	4.04	15.29	465	1,760	5,000	352		
5.5	140	3.40	12.87	390	1,476	5,000	352		

7,500 PSI Fluid End Cylinder

PISTON CYLINDER		DISPLACEMENT – DRILLING SERVICE				MAXIMUM PSI		PUMP RPM	JACKSHAFT RPM
DIAMETER		PER REVOLUTION		PER MINUTE		PSI	Kg/sq.cm2		
inch	mm	gallon	liters	gallon	liters				
7	178	5.5	20.82	632	2,392	3,905	275	115	504
6.5	165	4.74	17.94	545	2,063	4,527	318		
6	152	4.04	15.29	465	1,760	5,314	374		
5.5	140	3.40	12.87	390	1,476	6,324	445		
5	127	2.80	10.60	323	1,223	7,500	527		

Weight: Complete pump with large steel skid - 41,400 pounds.

Ratings are based on 90% mechanical efficiency and 100% volumetric efficiency.

**Gardner
Denver**
Pumping Perfected.™

PZL (PZ-11HP) Triplex Drilling Mud Pump



OPTIONAL FEATURES

- 7,500 PSI fluid
- Steel skid under pump only
- Large steel skid with non-skid decking
- Centrifugal suction charging pump
- Rubber valve inserts
- Suction and/or discharge dampeners
- Oil heat exchanger
- External electric powered lube pump
- Fabricated suction manifold
- Custom packaging available
- Full open valves

STANDARD FEATURES

- Nodular iron power frame, eccentric, connection rods, and crossheads
- Double-row-spherical roller bearings carry eccentric
- Double extended Jackshaft carried on heavy-duty straight roller bearings
- Dual roller bearing connecting rod
- Heat-treated alloy steel, interchangeable fluid cylinders
- Three-rib API-7 urethane insert valves and seats
- Replaceable-type element oil filer and oil pressure gauge
- Threaded valve covers
- Plated piston rods
- Complete piston washing and lubrication system

SPECIFICATIONS

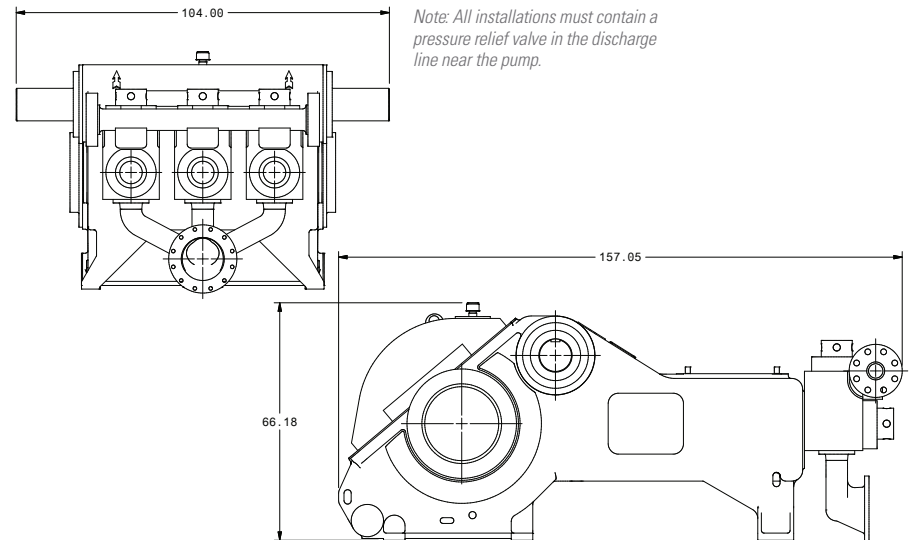

CONNECT WITH US: